

ST. LUKE PARISH

Bulletin — 000830

Address — 421 Cochise Ct.

Carol Stream 60188

Phone Number - 630/668-1325

Email—stloff@aol.com

Software — MSPublisher 2010

Adobe Acrobat X

Windows 7

Printer— Ricoh MP C2503

Contact - MARY LOU, 630/668-1325

NUMBER OF PAGES SENT —

1 through 8

SUNDAY DATE — June 18, 2017

Saint Luke Parish

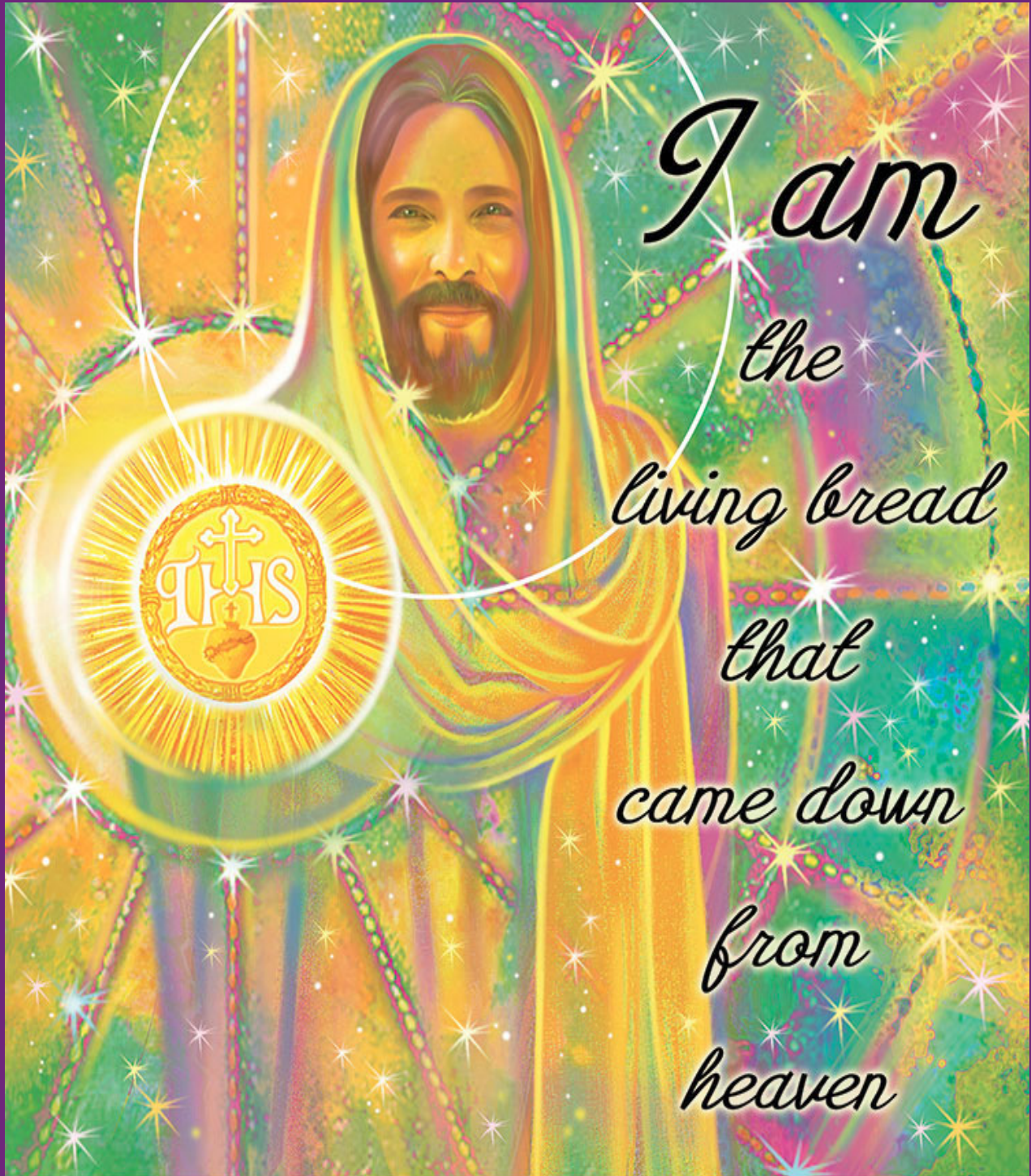

St. Luke Parish

Rev. Danilo Soriano
Pastor

Religious Education

Tel: 630/665-2322

stlrfp@aol.com

Parish Office Tel: 630/668-1325

Parish Office E-Mail: stloff@aol.com

Website: www.stlukecarolstream.org

the United States it was moved to the Sunday after Trinity Sunday. Even though Easter season ended two weeks ago, this beautiful feast is aglow with Easter light.

—Rev. James Field, Copyright © J. S. Paluch Co.

TRUST IN JESUS

Today's feast celebrates another central mystery of our faith—the mystery of the Eucharist. Like the mystery of the Trinity, the real presence of the Body and Blood of Christ in the Eucharist can never be fully understood, but can only be believed. Just as the Israelites in the desert were invited to put their trust in God's word to them, we are invited to trust wholly in the word of Jesus. In today's Gospel Jesus promises to give us a share in his very own flesh and blood, and a share in eternal life besides. We are called to take him at his word and open our hearts to receive true nourishment and life from our participation in the Eucharist.

Copyright © J. S. Paluch Co., Inc.

TREASURES FROM OUR TRADITION

At the heart of today's solemnity is a eucharistic procession, held in many parishes, that calls to mind the procession of Holy Thursday, yet has a purpose different from the somber adoration in the night watch. In the late Middle Ages, a procession through the city with the Blessed Sacrament was an occasion of heartfelt joy and great emotion. In a time when people seldom approached the altar to receive Holy Communion, the procession through the streets, past homes and workplaces, was a vibrant reminder that Christ was with them as a dear companion and guide.

Every year on this day, a joyful procession winds through the streets of Rome from the Lateran cathedral. A few years ago, Pope John Paul II, deeply moved at the sight of the throng accompanying the sacred host, said that we ought to feel profoundly united with the faithful everywhere in the world at such a moment. "Before our mind's eye all the Churches of the world, from East to West, from North to South, are present." Originally this feast was on the Thursday after Trinity Sunday, but after the calendar reform of 1970, its title was expanded from "Corpus Christi" to "The Body and Blood of Christ" and in

We all partake of the one loaf

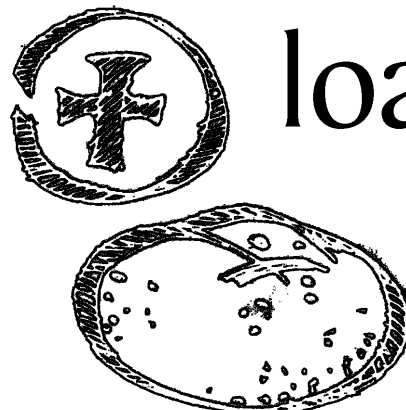

© J. S. Paluch Co., Inc.

MASSES CELEBRATED

DURING THE WEEK

ARE HELD

IN THE CHURCH

SATURDAY — JUNE 17

2:00pm — Baptisms

4:15 — 4:45 Confessions

5:00 — Joe Neff & Ed Breinig req. by Mary Breinig and
for Joseph Lewek req. by his children

SUNDAY — JUNE 18

8:30am — The People of St. Luke Parish

11:00 — Stan Solkowski req. by Del Carbone

MONDAY — JUNE 19

Mass will not be celebrated today

TUESDAY — JUNE 20

8:00am — The Intentions of the Celebrant

WEDNESDAY — JUNE 21

8:00am — The Intentions of the Celebrant

THURSDAY — JUNE 22

8:00am — The Intentions of the Celebrant

FRIDAY — JUNE 23

8:00am — The Intentions of the Celebrant

SATURDAY — JUNE 24

4:15 — 4:45pm Confessions

5:00 — John Angelo Jr., on the 4th Anniversary of his
death req. by his family

SUNDAY — JUNE 25

8:30am — The Intentions of the Celebrant

11:00 — The People of St. Luke Parish



Please pray for the sick in our parish especially, Pat Angelo, Yecenia Bosley, Joe Cavanagh, Angie Clift, Ralph Dinges, Disabled Vets, Jim Erickson, Angel Faulkner, Ed Jones, Audrey Race, Margie Rothchild, Bob Seitz and Jim Wright.

Please remember our beloved dead, especially Deacon Paul Brachle, Irene Greer and the men and women who have given their lives for our country.

WHAT IS A MASS INTENTION?

A person may ask for a Mass Intention for several reasons: for example, in thanksgiving, for the intentions of another person (such as on a birthday), or, the most common, for the repose of the soul of someone who has died.

When a priest offers Holy Mass, he has three intentions: First, to offer the Mass reverently and validly in accord with the norms of the Church. Second, to offer the Mass in union with the whole Church and for the good of the whole Church. Third, to offer the Mass for a particular intention, such as the repose of the soul of someone who has died.

When we face the death of someone, even a person who is not Catholic, to have a Mass offered for the repose of his soul and to offer our prayers are more beneficial and comforting than any other sympathy card or bouquet of flowers. To have a Mass offered on the occasion of a birthday, anniversary or special need is appropriate, beneficial and appreciated.

If you would like to request a Mass for someone, we request at least a week notice. We understand the importance of having a Mass said and want to make sure we do right by everyone. The Mass stipend is \$10.00.

If you want to make sure it appears in the bulletin, we need at least 2 weeks.

You can call the office at 630/668-1325 Monday thru Thursday between 9:00-4:00 or Friday between 9:00-12:00 to request a Mass.

TODAY'S READINGS

First Reading — Never forget the LORD your God, who brought you out of slavery and fed you with manna in the desert (Deuteronomy 8:2-3, 14b-16a).

Second Reading — Because the loaf of bread is one, we who partake of it, though we are many, are one body (1 Corinthians 10:16-17).

Gospel — Jesus said to the crowds, "I am the living bread; whoever eats this bread will live forever" (John 6:51-58).

The English translation of the Psalm Responses from *Lectionary for Mass* © 1969, 1981, 1997, International Commission on English in the Liturgy Corporation. All rights reserved.

READINGS FOR THE WEEK

Monday: 2 Cor 6:1-10; Ps 98:1, 2b, 3-4; Mt 5:38-42
Tuesday: 2 Cor 8:1-9; Ps 146:2, 5-9a; Mt 5:43-48
Wednesday: 2 Cor 9:6-11; Ps 112:1bc-4, 9; Mt 6:1-6, 16-18
Thursday: 2 Cor 11:1-11; Ps 111:1b-4, 7-8; Mt 6:7-15
Friday: Dt 7:6-11; Ps 103:1-4, 6-8, 10; 1 Jn 4:7-16; Mt 11:25-30
Saturday: Vigil: Jer 1:4-10; Ps 71:1-6, 15, 17; 1 Pt 1:8-12; Lk 1:5-17 Day: Is 49:1-6; Ps 139:1-3, 13-15; Acts 13:22-26; Lk 1:57-66, 80
Sunday: Jer 20:10-13; Ps 69:8-10, 14, 17, 33-35; Rom 5:12-15; Mt 10:26-33

**Welcome
New
Members**

© J. S. Paluch Co., Inc.



We would like to welcome our newly registered parishioners for the month of May

John and Maria Delvalle & family on Edgebrook Ct
Ronald and Michelle Lehmkuhle & family on Tomahawk Ct
Linda and Derek Mast & family on Ohio Ct
Jerry and Rachael Mennes & family on Sioux Ln
Scott Vanden-Heuvel on Colorado Ct
Joe Zaremba on Cochise Ct

COUNCIL OF CATHOLIC WOMEN

During Lent, our Council of Catholic Women Church Commission asked St. Luke members to donate some toys and/or craft supplies to the new DuPage County Family Center in Wheaton. Two CCW volunteers, Cyndi Holich and Gail Sanders were warmly received when they delivered several large bags of donations to the Center. We received the following thank you note:

Dear St. Luke CCW and Parish,

Just a quick note to show gratitude for all the wonderful toys you donated to the Family Center. We kept a few to use with families in our supervised parenting time program—particularly the craft items. The others are available for needy children to take home. We have already given a few to some children and have more to last awhile! Thank you again! I am so grateful to you— it allows us to give toys away when children need them the most— during times of conflict at home.

Sheila Murphy-Russel, Director
DuPage Family Center

THANK YOU

CCW and Lifesource would like to thank all who donated in the recent blood drive on June 4th in Jericho. We received 13 donations which will go a long way towards helping those in need of blood.

Congratulations to Jim Kelly who was our gift card winner

MUSIC MINISTERS SOCIAL GATHERING!

On Tuesday, June 20th at 7:00pm all Music Ministers from the Joliet Diocese are invited to attend a social gathering at St. Isaac Jogues Church, 306 West 4th Street, Hinsdale, in the parish "Fireplace Room". This is an opportunity for all musicians to meet other Joliet Diocesan musicians, learn more about the Joliet NPM Chapter and discuss future programs that the chapter will offer for the up-coming year. The chapter would like your thoughts and ideas for programming the next season! Come and enjoy an evening of conversation, prayer, song and wine and cheese!!

Please RSVP by June 18th to www.NPMJoliet@gmail.com or Mary Bolton, 630/793-9276. We hope to have a large turnout! This is a great opportunity to meet, great and share ideas about what is happening at YOUR parish and in the diocese.

For more information contact Chapter Director, Nick Thomas at nick@sijhinsdale.com. Hope to see YOU on June 20th!

“CELEBRATE AMERICA!”

at the 22nd Annual Senior Lifestyle Expo on Tuesday & Wednesday, August 22nd & 23rd at Drury Lane Oakbrook Terrace from 9:00am — 2:00pm.

Get connected at Chicagoland’s largest event targeted to active adults, the Senior Lifestyle Expo! This is your opportunity to enjoy entertainment, information and fun, all under one roof.

- Health and Wellness Screenings
 - Outstanding Entertainment
 - “Senior Idol” Competition
 - Connecting the Generations Writing Challenge
 - Interesting & Educational Seminars
 - Interactive Game Show Challenge
 - Drawings and Giveaways
 - 100+ Product and Service Exhibitors
- Save the dates now. For more information call Katie at 630/293-5990.

Senior Idol & Writing Challenge Applications are available, just ask or you can download applications at www.seniorlifestyleexpo.org.



Inspiring medicine. Changing lives.

Eat Well, Be Well

The percentage of Americans with diabetes has nearly doubled in the past two decades, according to a new study in the Annals of Internal Medicine. While genetics often plays a role in whether or not you have diabetes, lifestyle also makes a big difference, both in preventing diabetes and in managing it once you are diagnosed. Eating well is especially important.

Follow these simple, healthy eating tips:

- Do not skip meals. Eat at least three well-balanced meals each day.
- Eat at consistent times every day and space meals to no more than five hours to six hours apart.
- Avoid concentrated sweets: regular syrups, sugar, honey, jam, jelly, hard candy, cake, pie, cookies, chewing gum, soft drinks and fruit drinks.
- Include fiber-rich foods in a daily meal plan by choosing whole grain breads, cereals, fresh fruits and vegetables and dried beans.
- Use fresh fruits or canned fruits packed in water or natural juices. Avoid fruit canned in “heavy” or “lite” syrups. All juices should be 100 percent fruit juice, unsweetened or “no added sugar.”
- Remember that “sugar-free” labels on foods, such as cakes, cookies and candies, does not mean the foods can be eaten freely and are completely sugar-free. Check labels for grams of total carbohydrates.
- Bake, broil or roast meats. Avoid frying or breading meats. Avoid adding extra servings of butter, margarine or cream sauces to vegetables.

In our faith communities, we can recognize how diabetes impacts our members and be intentional about how we share meals together. Start a “Healthy Potluck” policy that asks people to bring dishes that follow the tips above. Don’t serve beverages that are loaded with sugar. Be aware of people for whom eating well may be difficult—isolated seniors, people with disabilities, those with limited resources—and talk with them about what they would find helpful. How we live together in community can literally change someone’s life!

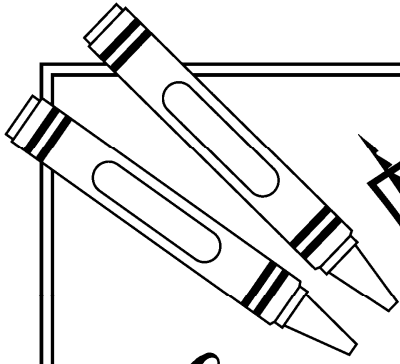

PUZZLE

Our heavenly Father

Father's Day is the perfect time to remember God, our heavenly Father. What does the psalmist say about him?

Directions: Complete Psalm 89:26 by placing the correct vowels in the blanks.

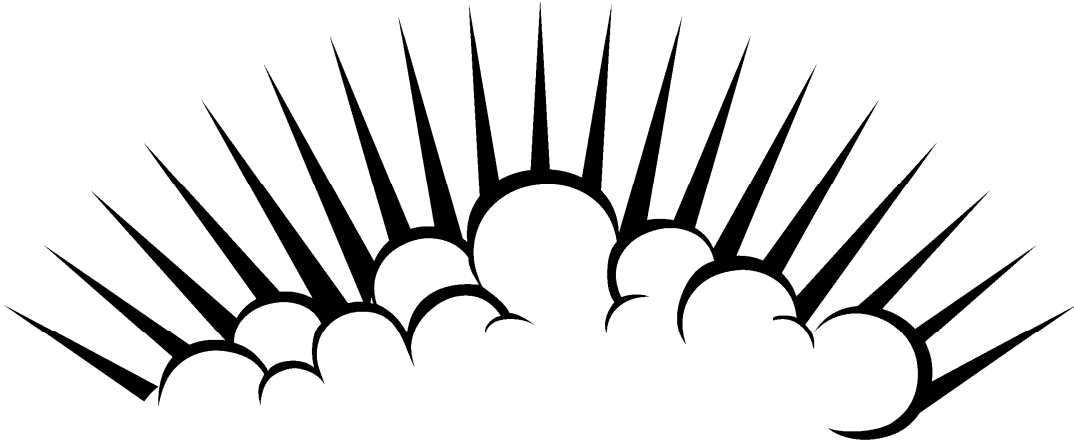

"H_ w_ll c_ll _ _ t t_ m_ ,

'Y_ _ _ r_ m_ F_th_r, m_

G_d, th_ R_ck m_ S_v_ _ r.'" "

Ps_Im 89:26, N_V

Answer: "He will call out to me, 'You are my Father, my God, the Rock my Savior.'" Psalm 89:26, NIV

Thanks Dad!



Happy Father's Day

STAFF OF LIFE

Bread is the staff of life.

—English saying

FATHERHOOD

Blessed indeed is the man who hears many gentle voices call him father!

—Lydia M. Child

THE BEST FATHER

Unlike an earthly prince, God didn't take a high-and-mighty title, notes 17th-century British preacher Thomas Watson. Instead, God calls himself Father to encourage us to pray to him.

But God isn't just any father. Watson offers these reasons why God is "the best Father":

- He is the most ancient (Daniel 7:9).
- He is perfect (Matthew 5:48).
- He is the wisest (Romans 16:27).
- He is the most loving (Zephaniah 3:17; 1 John 4:16).
- He has unsearchable riches (Ephesians 3:8).
- He can reform his children (Acts 9:11).
- He never dies (1 Timothy 6:16; Revelation 1:8).